



# Cutting System L-R-High-Speed Cutter-T

The standard POLAR Cutting System with exact preparing of the cutting material, manual loading and automatic lowering the cut products on the pallet.

## Customer benefits

- Up to 180 % more output (operation with 2 persons) adverse a High-Speed Cutter without peripheral equipment
- Improved ergonomics, because lifting heavy loads drops when loading or unloading
- The precise alignment of the cutting reams in the automatic jogger improves the quality considerably
- The High-Speed Cutter offers a big economic potential thanks POLAR OptiKnife, easiest operation, first class service and best resale value
- Consistent stacking quality allows direct processing in the printing / folding machines

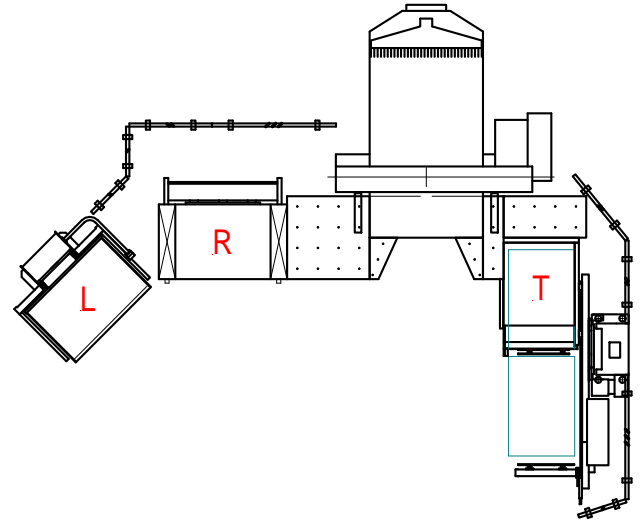

## Description of the machine

The Stack Lift allows the operator loading the material into the jogger at an ergonomic height via lifting automatic the material to be cut.

The precise alignment of the material to be cut, and the resulting improved cutting accuracy lays the foundations of a uniform and high quality of the final product. In conjunction with the air removal feature improves the formation of blocks from the reams to be cut and reduces the production risks once more.

The core component of the Cutting System is the POLAR High-Speed Cutter. The high speed cutter has extensive features in the standard equipment already which can increase the productivity clearly.

It is no longer necessary to take off the intermediate or finished products laboriously by hand, but they are simply pushed onto the transport pallet of the Transomat unit. It automatically deposits parted or complete reams on a pallet. Simultaneously, the operator can continue cutting, which improves the efficiency of the high-speed cutter substantially.

## Available format ranges

	Diagonal [cm]	Stack Lift (L) recommended (alternative)	Automatic Jogger (R)	High-Speed Cutter recommended (alternative)	Transomat (T) recommended (alternative)
63 x 88	109	LW 1200-4 (S-FA-3)	R-4 / RA-4	POLAR 115	TRE 130-4 (TRE 90-4)
75 x 105	129	LW 1200-4 (S-FA-3)	R-4 / RA-4	POLAR 137 (115)	TRE 130-4
89 x 126	155	LW 1200-6 (S-FA-6)	R-6 / RA-6	POLAR 155 (137)	TRE 130-5 (TRE 160-6)
102 x 142	175	LW 1200-6 (S-FA-6)	R-6 / RA-6	POLAR 176 (155)	TRE 160-6
121 x 162	203	LW 2000-7S	RA-7S	POLAR 176	TRE 160-7S

For smaller sizes we approve our Cutting System L-R-78-L or L-R-92-L.

Technical data for individual components are available for download on our website.